

# S6100

1998.5-2002 Dodge 2500/3500  
5.9L CUMMINS, Turbo-Back, 4.0" Single Side

# MBRP®

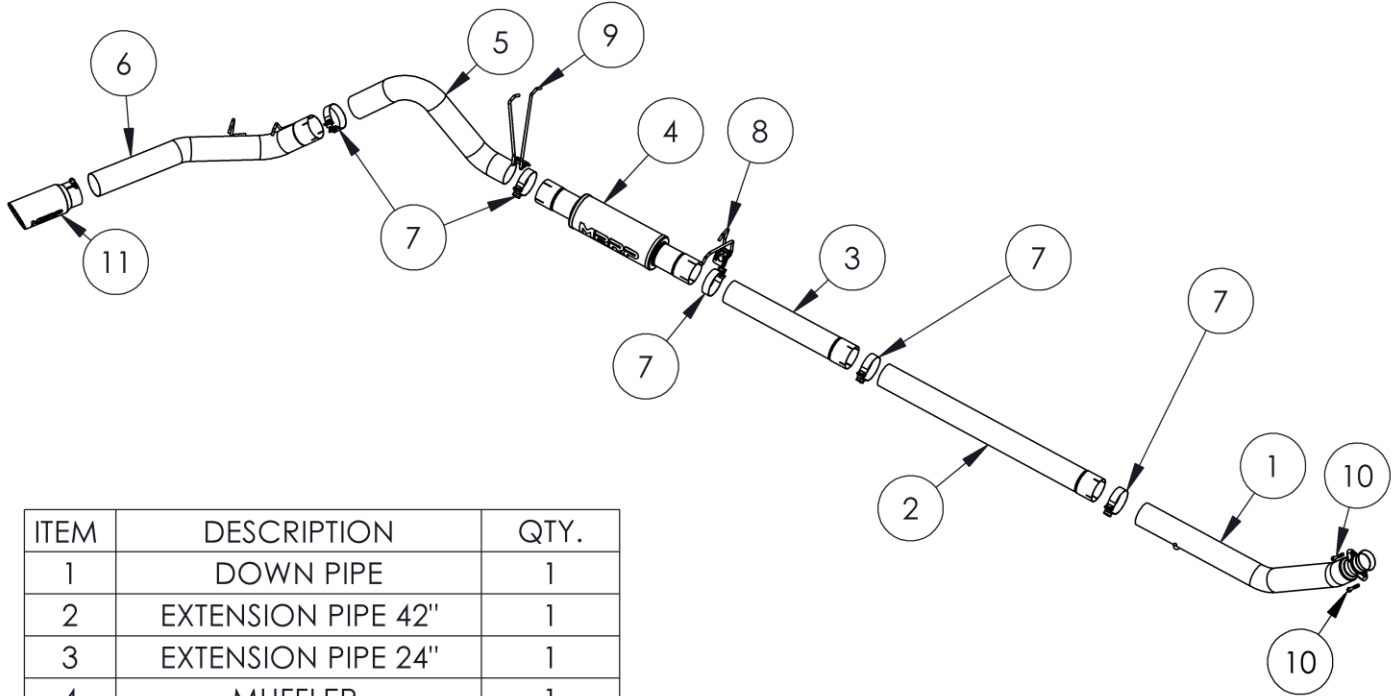

ITEM	DESCRIPTION	QTY.
1	DOWN PIPE	1
2	EXTENSION PIPE 42"	1
3	EXTENSION PIPE 24"	1
4	MUFFLER	1
5	OVER-AXLE PIPE	1
6	TAIL PIPE	1
7	4" BAND CLAMP	5
8	FRONT HANG TIGHT™	1
9	REAR HANG TIGHT™	1
10	M10 X 60MM BOLT	2
11	EXHAUST TIP	1

Refer to this LOT NUMBER when contacting customer service: \_\_\_\_\_

## PLEASE READ BEFORE STARTING INSTALLATION

While MBRP has made every effort to ensure that all components of this system are of superior quality and properly packaged, it is the installer's responsibility to ensure the following before removal of the factory exhaust:

- that ALL components shown above are present.
- that ALL mating components fit together.
- that there are no damaged components.
- that the system you have purchased is appropriate for your vehicle year, model and configuration.
- that the system will not interfere with any modifications previously installed or planned.
- that you have read and understand these instructions.

If you have any questions or are uncertain about any aspect of the installation of this system to your vehicle please contact your dealer before commencing installation.

# MBRP

## Removal of Stock System:



Figure 1

1. Separate the stock exhaust system at the slip joint by the muffler. Remove the rear exhaust from the rubber hangers and remove the system from under the truck.
2. Using a socket or wrench, remove the two bolts at the turbo flange and remove the stock down pipe.

## Installation of MBRP Performance Exhaust:



Figure 2

1. Install the **Down Pipe** starting from behind the cross member and place it in the same position as the stock down pipe. Place the hanger into the OEM rubber insulator and attaching the flared end to the turbo using the supplied **M10 x 60mm Bolts**. Do not fully tighten until all components are in place. **Refer to Figures 1 & 2.**

2. Install the **42" Extension Pipe** and **24" Extension Pipe** over the **Down Pipe** using the **4" Band Clamps** provided. The combination of these two **Extension Pipes** provides the required length to fit a Quad Cab Long Bed truck, for Quad Cab Short Bed cut the **42" Extension Pipe** to 26" and for Regular Cab Models cut down to 22". **Refer to Figure 3.**



Figure 3

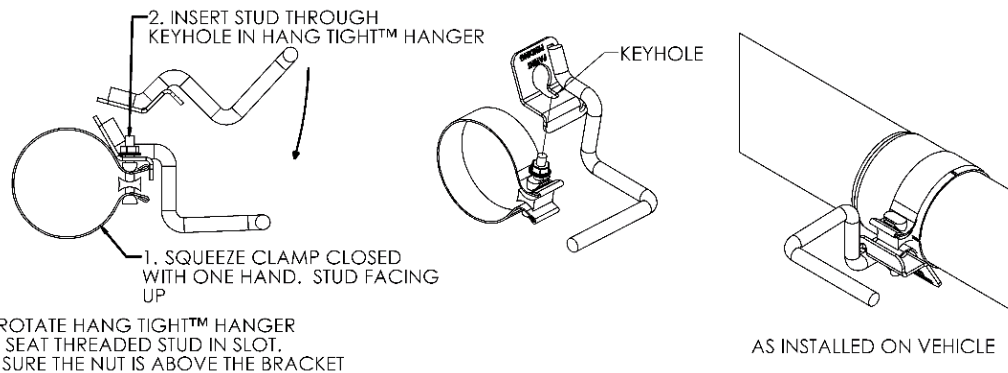

Figure 4 (Hanger not as shown)

# MBRP



Figure 5



Figure 6

(Hanger may not be as shown)



Figure 7



Figure 8

3. Slide the **Front Hang Tight™** (see **Figure 4** for Hang Tight™ instructions) over the inlet of the **Muffler**. Then install the **Muffler** over the **Extension Pipe** and place the **Front Hang Tight™** into the OEM rubber hangers above the inlet. (Muffler orientation: Louver openings should face the rear of the vehicle).  
**Refer to Figures 5 & 6.**
4. Slide the **Rear Hang Tight™** over the outlet of the Muffler and place the **Rear Hang Tight™** into the OEM rubber hangers above the outlet.
5. Install the **Tail Pipe** and **4" Band Clamp** onto the **Over- Axle Pipe**. From the rear of the truck, Slide the assembly over the axle and attach to the outlet of the **Muffler**. Install Tail Pipe hangers into the OEM rubber hangers. Refer to Figure 7.
6. Install and adjust the **Exhaust Tip** to suit. Tighten the lock bolt located on the **Exhaust Tip**. Refer to **Figure 8**.
7. Tighten all hardware and clamps, starting at the front and working rearward to secure the system. Check along the full length of the exhaust system to ensure there is adequate clearance for fuel lines, vent lines, brake lines, frame, bodywork, suspension, and any wiring, etc. If there is any interference detected, relocate, or adjust to provide adequate clearance. Ensure all clamp connections are secure and components are unable to rotate or slide. Band clamps require approximately 45 lb-ft (60 N-m) of torque. Verify clearances, system security and band clamp torque after 30-60 miles (50-100 km) of driving.

**Congratulations!** You are ready to begin enjoying the improved performance and driving experience of your MBRP performance exhaust system. We hope you enjoy your purchase.